

## WH-C4 Chain Hoist



The William Hackett WH-C4 chain hoist meets and exceeds the requirements of the following international standards:

British Standard BS EN13157:2004 + A1:2009

American Standard ASME B30.16-2012

Australian Standard AS1418.2-1997

South African Standard SANS 1594:2007

NORSOK R-002: 2017.

The William Hackett WH-C4 chain hoist is manufactured in accordance with EN13157 which requires that it can be used within an operating temperature range of -40°C to +55°C.

The design and specification of the William Hackett WH-C4 chain hoist includes:

- **WORKING LOAD LIMIT RANGE:** 500kg to 50 tonnes.
- **LIGHT LOAD CAPABILITY:** the WH-C4 is tested and certified at 2% of the chain hoist rated capacity.
- **TWIN PAWL:** double safety; fitted as standard.
- **SAFETY LATCHES:** the WH-C4 chain hoist top and bottom hooks are fitted with heavy duty cast steel latches. The latch and hook tip are integrated creating a strong and robust hook closure.
- **OVERLOAD INDICATOR MARKS:** WH-C4 chain block top and bottom hooks have, as part of the hook forging, overload indicator

GPS LIFTING

18 CHURCH STREET, ASHTON-UNDER-LYNE, LANCASHIRE OL6 6XE

marks either side of the hook throat. By measuring the distance between the indicator marks, the hook can be quickly and easily checked to see if any stretch has occurred due to misuse or overloading.

- **HAND CHAIN JOINER:** a unique hand chain joiner is used as a quick and secure method of joining the hand chain without the need to cut, bend, open and close a link of existing hand chain.
- **HOOK HOUSING:** the WH-C4 chain hoist top and bottom hook housing are secured with socket head cap screws/hex head bolts and nyloc insert locking nuts.
- **FLEETING/CROSS HAULING:** the WH-C4 chain hoist is tested and certified for fleeting or cross hauling applications up to 45° from the vertical without deration.
- **LOAD CHAIN:** WH-C4 chain blocks are fitted with load chain that fully complies with international standard BS EN818-7 Grade T (8).
- **OVERLOAD LIMITER:** available as an option upon request.

## Specifications

### Single Fall

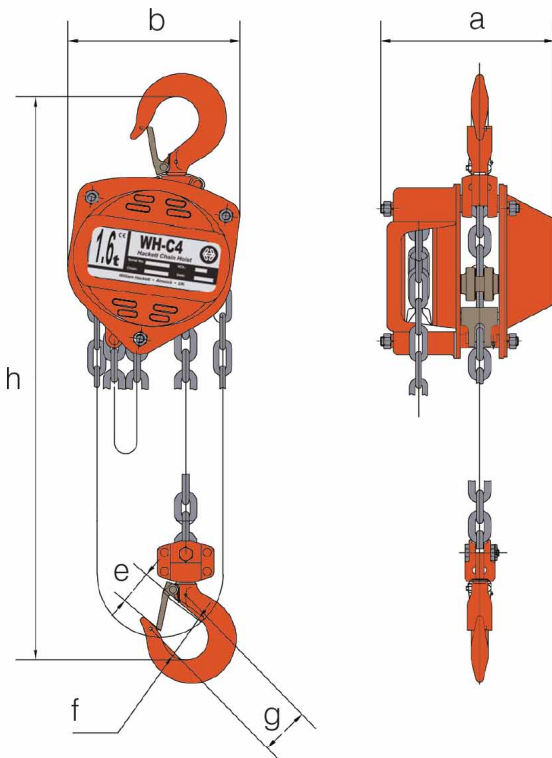

### Multi Fall

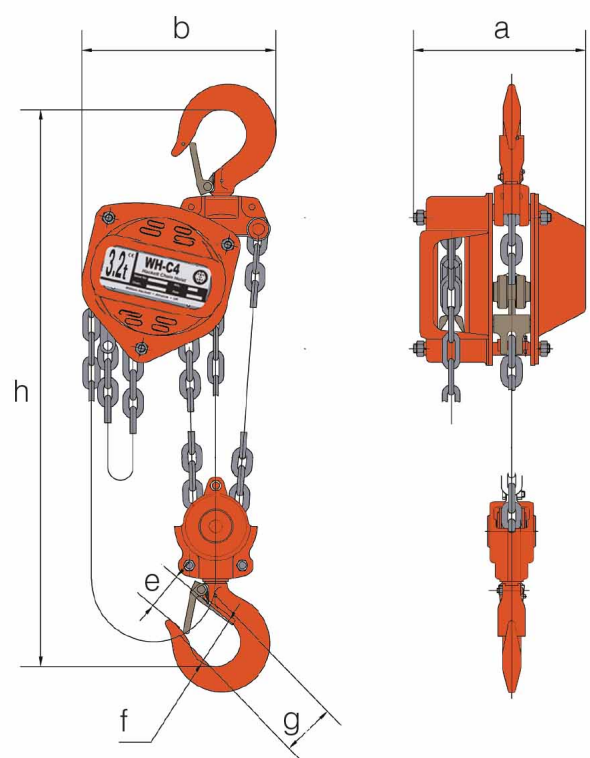

Part Code	WLL tonnes	No. of Falls	Load Chain mm	Hand Chain mm	Standard Lift m	a mm	b mm	e mm	f mm	g mm	h mm	Mass kg	Extra Weight per M kg
022.050	0.50	1	5 x 15	5 x 25	3	125	130	22.5	32	37	280	7.80	1.38
022.100	1.00	1	6 x 18	5 x 25	3	134	155	26.5	40	44	306	11.10	1.62
022.160	1.60	1	8 x 24	5 x 25	3	151	173	32.5	42	48	368	15.80	2.23
022.200	2.00	1	8 x 24	5 x 25	3	157	185	36.5	46	52	445	16.80	2.23
022.32D00	3.20	2	8 x 24	5 x 25	3	157	235	43.5	52	62	520	24.20	3.62
022.500	5.00	2	10 x 30	5 x 25	3	180	262	51.0	60	77	600	39.80	5.18
022.750	7.50	3	10 x 30	5 x 25	3	192	373	64.0	85	-	740	72.40	7.60
022.1000	10.00	4	10 x 30	5 x 25	3	180	365	53.0	85	-	760	89.70	9.52
022/1500	15.00	6	10 x 30	5 x 25	3	210	406	80.0	100	-	1000	91.10	13.86
022/2000	20.00	8	10 x 30	5 x 25	3	225	550	80.0	110	-	1150	197.00	19.03
024/3000	30.00	12	10 x 30	5 x 25	3	360	680	80.0	110	-	1250	301.00	27.71
024/5000	50.00	20	10 x 30	5 x 25	3	585	832	133.0	170	-	1700	465.00	45.80