

Supplied by GPS Lifting Ltd www.gpslifting.co.uk

Instruction Manual

DRUM GRAB



Note: The Owner/Operator must read carefully and understand all the information presented here before operation.

Contents

1	Structure and relevant parts description.....	2
2	Specification.....	3
3	Unpacking.....	3
4	General safety information.....	3
5	Operation.....	4
6	Maintenance.....	6
7	For warranty service.....	6
8	For non-warranty service.....	6

THANK YOU FOR CHOOSING OUR DRUM GRAB. FOR YOUR SAFETY AND CORRECT OPERATION, PLEASE CAREFULLY READ THE MANUAL BEFORE USE.

NOTE: All of the information reported herein is based on data available at the time of printing. The factory reserves the right to modify its own products at any time without notice or incurring in any sanction. Please verify with the factory for possible updates.

1. STRUCTURE AND RELEVANT PARTS DESCRIPTION

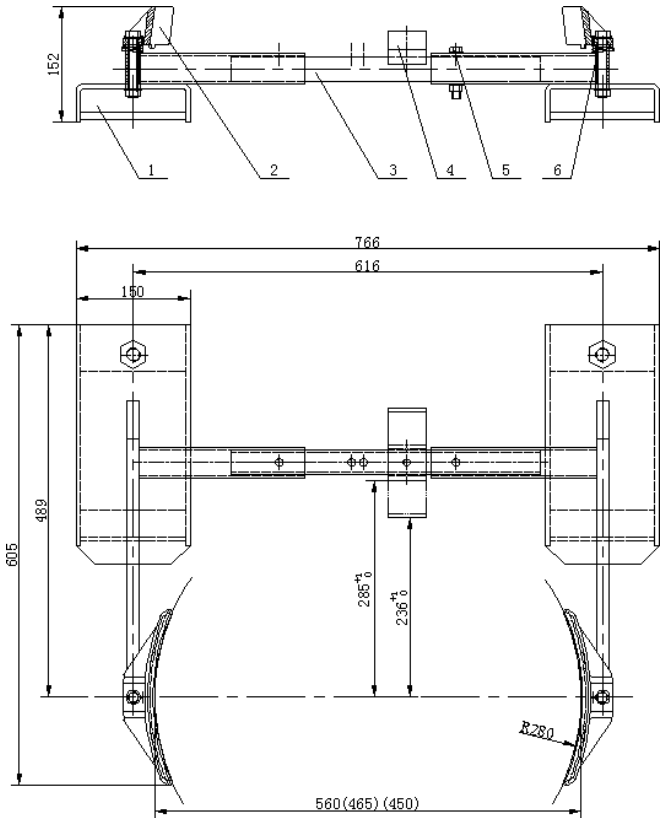

Item No.	Description	Remark
1	Supporting rack	
2	Clamp	
3	Adjustable axle	
4	Clamp	
5	Bolt	
6	Spring	

LOAD RATING: 1000lbs/per drum, 30 or 55 gallon drum

2.SPECIFICATION

Model	Drum Type	Capacity (lbs / per drum)	Drum (gallon)	Fork Pockets (Inch)	Net weight (lbs)
DG50	Adjustable, Single Poly Drum	1000	30 or 55	5 ³ / ₈ *1 ¹ / ₂	41

3.UNPACKING

When unpacking your unit, check carefully for shipping damage.

4. GENERAL SAFETY INFORMATION

WARNING: The Drum Grabs are designed for specific functions. To insure proper use, the following instructions must be adhered to:

1. DO NOT USE YOUR UNIT FOR LOADS EXCEEDING THE RATED CAPACITY.
2. The Drum Grabs are designed for use only with the drums shown the previous list. Do not use for open head drums containing liquid or powder. Do not use on fiber or plastic drums. Drums must have rolling ribs and should not be severely dented or otherwise misshapen.
3. Adhere to all local codes regarding drum use and storage.
4. Before using this product contact the manufacturer of your industrial truck and obtain their written approval that the truck has the capacity to be used with this attachment.
5. Don not use drum grabs with manually operated stackers.
6. Do not use to lift personnel or to carry loads over people.
7. Do not leave with a loads suspended in air unattended.
8. Do not remove or obscure capacity warning label.
9. Inspect unit daily before use. Remove unit from service immediately if faulty until such time as repairs have been made.
10. Do not modify this product in any way.
11. Use only genuine replacement parts with the manufacturer offered when servicing.

5. OPERATION

The following outlines the general operation of Drum Grabs. Differences for specific models follow this section.

1. Place unit on floor or flat surface easily accessible to fork truck. Be sure that “T” bolts are sufficiently unthreaded to allow forks to enter pockets.
2. Carefully slide forks (do not use fork extensions) into drum grab's fork pockets. Be sure forks are in pockets as far as possible.
3. Hand tighten “T” bolts to secure unit to forks (hand tool may be used but is not necessary) Recheck bolts periodically during use for tightness.
4. If not already done, unfold grab jaws.
5. Raise unit and approach drum so that the jaws come in contact with the drum just below the upper rolling rib of the drum. (Figure 1)



Figure 1

6. Move unit forward onto drum, lowering jaws slowly as you move. Jaws will open and close around drum. (Figure 2)



Figure 2

7. When jaws surround drum, raise forks until jaws rest under upper rolling rib. Drum can now be raised and moved where desired. (Figure 3)
8. To release drums, return to floor, lowering drum grab slowly as you pull back.



Figure 3

9. Follow same procedure with two drums at same time. For easier pickup, drums should touch each other. Be sure that drum weights are similar to insure balanced load.

10. **Adjusting Jaws:** Jaws must be properly positioned for 55 or 30 gallon drums by raising to 90 degrees and sliding jaws to location on shaft.

6. MAINTENANCE

Lubricate moving parts periodically

7. FOR WARRANTY SERVICE

If unit does not work properly, contact your dealer or the factory for units less than ninety days old.

8. FOR NON-WARRANTY SERVICE

For units older than ninety days, repairs can be made easily with factory authorized parts.

NOTE: Do not send units to the factory for service without obtaining a “returned goods authorization number” from the service department. We will not be responsible for goods returned without proper authorization